

Accurpress Precision Forming Systems

Accell E

THE COMPETITIVE EDGE



Accell U

UPGRADE PACKAGE



ACCURPRESS

Accurpress

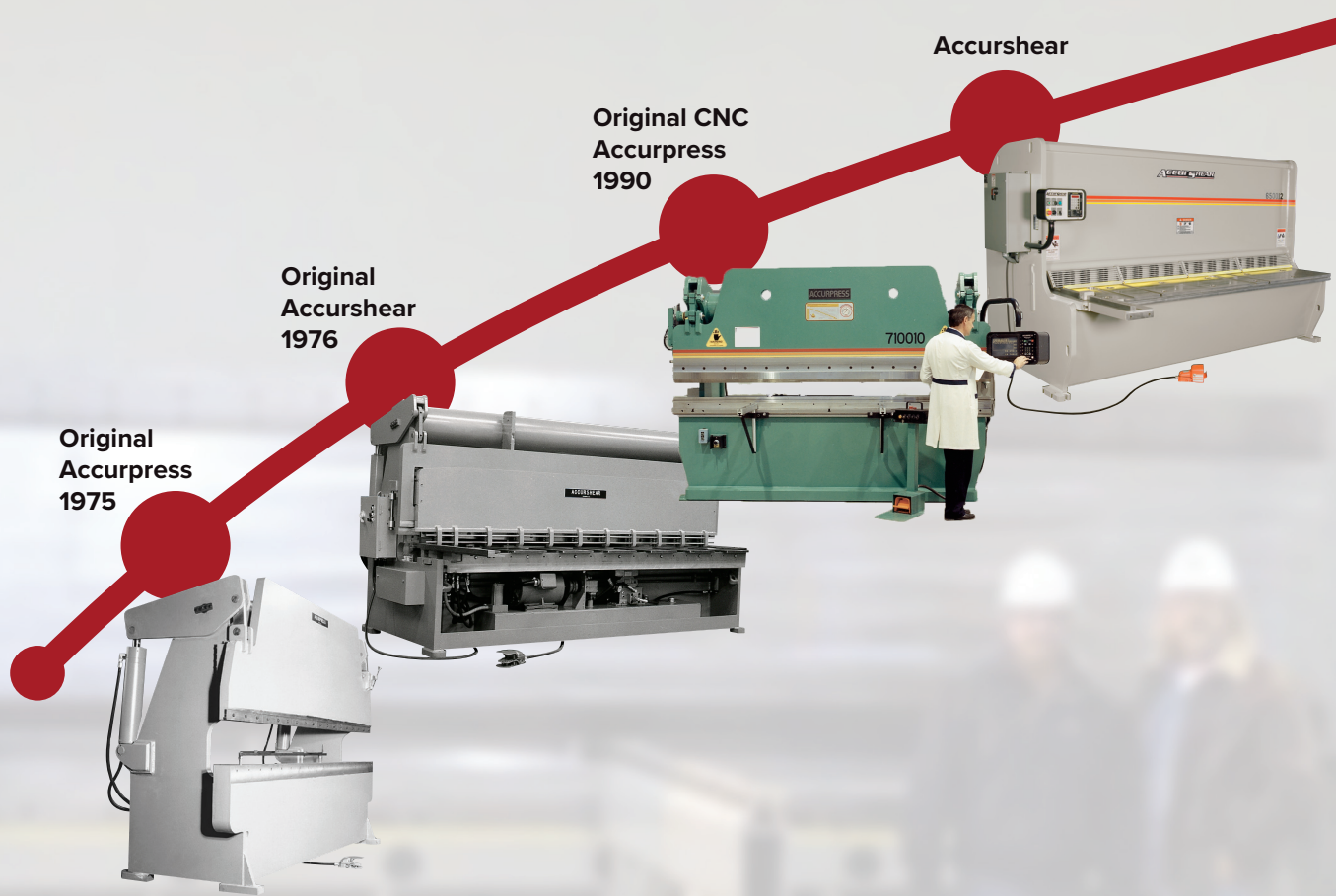



About Us

With over 45 years in the marketplace, Accurpress continues to build on its tested history to manufacture an innovative and complete line of press brakes and shears for every bending and shearing application. Proudly North American made, Accurpress leads the way with high tonnage machines, revolutionary pole bending technologies, tandem machines, and robot automation. With over 21,000 machines sold to thousands of satisfied customers, Accurpress continues to build press brakes and shears to meet the demands of today's manufacturing environments.

“While 45 years have brought huge changes to the machine tool industry, all of us at Accurpress continues to stand firm on the original foundation of quality that the company was built on. Every Accurpress machine, including the one you'll buy, is made with 100% of our best efforts. Our business depends on it and so does yours.”

Steve Hilton
President

The **ACCELL** Lineup

A Complete Line of Y1/Y2 Machines

Accell E

THE COMPETITIVE EDGE

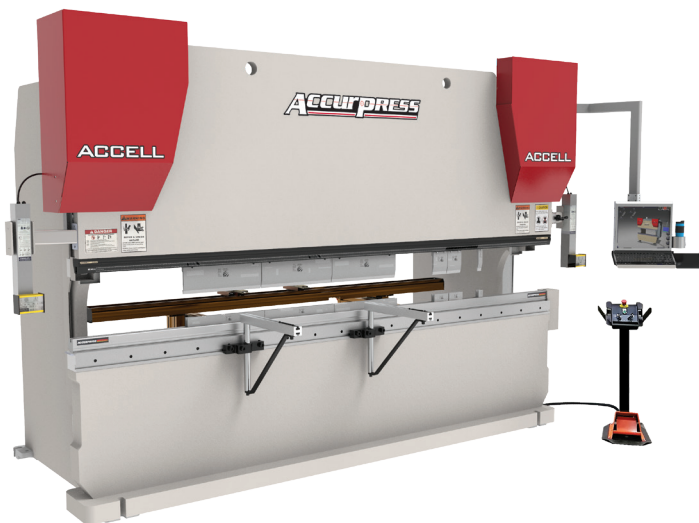

Available from 75-500 Tons

The **Accell E** is the complete package. With a high-quality build, an impressive number of features and options, competitive pricing and advanced controls, this is your first choice in Y1/Y2 machine technology.

Accell U

UPGRADE PACKAGE



Available from 90-550 Tons

The **Accell U** Upgrade Package builds on the already impressive standard features of the machine to provide even more functionality and flexibility. This specialized machine can handle any forming challenge or production run with ease.

Accell H

HYBRID TECHNOLOGY



Available from 60-190 Tons

The **Accell H** exceeds performance expectations with its high-speed forming and ability to tackle any application challenge. With advanced motion technologies and the most flexible features and options, the Accell H is the ultimate in creating complex parts.

Reference **ACCELL H Brochure** for a complete list of features and options.

Accell HT

HIGH TONNAGE



Available from 650-3000 Tons

The **Accell HT** features rugged builds, oversized components, and powerful gauging devices. These machines are tough and durable and will stand up to any forming challenge. If you want to bend something big, we've got you covered.

Reference **ACCELL HT Brochure** for a complete list of features and options.

The **ACCELL E**

75-500 Ton Models

Your first choice in Y1/Y2 machine technology! With its quality build, an impressive number of features and options, advanced Vision Control and competitive pricing, the Accell E is the total package.



THROAT DEPTH

12" Throat Depth on machines up to 250 Tons.
14" Throat Depth on 350–500 Ton models.

UL Approved Electrical Standards

Electrical cabinets are assembled and wired to the applicable and current UL approved standards.

FRONT SUPPORT ARMS

Swing-stock arms mounted to the front of the bed, slide left-right via the machine t-slot on the face of the bed.

Y1/Y2 PROPORTIONAL HYDRAULIC TECHNOLOGY

The Accell E has the latest in proportional hydraulic technologies allowing for positional accuracies of 0.0004". Machine reliability is monitored via a Safety PLC.

CONTROL HEAD WORK STATION [See P. 10-11]

The Vision control display has a convenient area for a keyboard, mouse, and even your coffee mug!

HYDRAULIC RAM CLAMPING [See P. 20]

All E-models are equipped with Wila Hydraulic Ram Clamping to suit American tooling. Wila New Standard Pro or Premium is available as an option.

GENEROUS OPEN HEIGHT/STROKE LENGTH

The Accell line comes standard with impressive ram open heights and stroke lengths to provide flexibility for complex part designs.

OFF CENTER BENDING

The integrity of the frame provides for precision off-center bending applications. Additionally, the advanced control allows for the creation of CNC fade bends.

CNC CROWNING

The CNC Accurcrown offers flexibility and accuracy to the full range of bending applications by compensating for machine deflection during forming. This feature is standard for all 4125xx-4500xx ton models. The 475xx models come standard with the Accurpress non-crowning Die Holder.

BACKGAUGE OPTIONS [See P. 12-15]

Accell E models include the Premium CNC X, R, (optional Z1/Z2) backgauge. The optional Elite backgauge offers greater flexibility in 6-axes X1/X2, R1/R2, Z1/Z1.

The **ACCELL U**

The Accell U Upgrade Package builds on the already impressive standard features of the machine to provide even more functionality and flexibility. This specialized machine can handle any forming challenge or production run with ease.



OPTIONAL PRECISION SHEET SUPPORTS [See P. 17]

The bed of the machine is prepared for optional Precision Sheet Supports. This allows for the easy installation of these support fixtures at any point.

UL Approved Electrical Standards

Electrical cabinets are assembled and wired to the applicable and current UL approved standards.

UPGRADE PACKAGE

INCREASED TONNAGE CAPACITY RATINGS

Models	Max Tons
575xx	90
5125xx	150
5175xx	190
5250xx	285
5350xx	385
5500xx	550

The U-model UPGRADE frame is increased in weight to permit additional tonnage capacity without compromising the structural integrity or bed/ram deflections under full load.

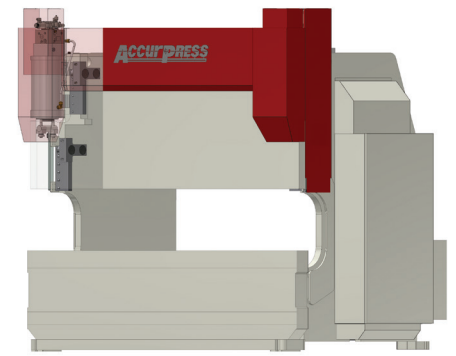
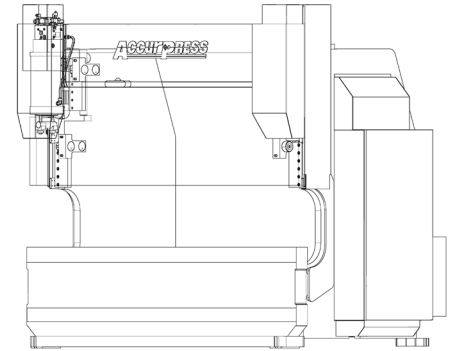

DOUBLE BENDING SPEED

An added bonus with the U-model package is the two-speed bending feature which increases from 24 to 48 IPM. This feature is available on the 575xx to 5500xx models.

EXTRA STROKE LENGTH

The Upgrade Package means 14-inches of Ram Stroke Length to provide generous allowances for the variation in precision punch heights and special forming applications. Optional Ram Stroke Lengths are available beyond the standard 14-inch upgrade package.

MATERIAL COMP FEATURE [See P. 16]

Material Thickness Sensing, Teach Crowning and Pressure Compensation all provide real-time positional adjustments based on material variance.

THROAT DEPTH INCREASE

Models	Inches
575xx	16
5125xx	16
5175xx	16
5250xx	16
5350xx	18
5500xx	18

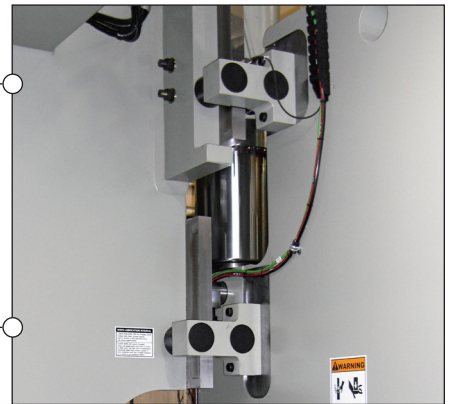

- The U-models from 575xx to 5500xx utilize a 4-point Ram Guiding system to provide the ultimate in machine motion and stability under the full load increased tonnage capacities for each model.
- The System incorporates large rollers/hardened ways for low friction and is an integral aspect of the COMP Feature to ensure exceptional accuracies in a wide range of bending applications.
- The Guiding System ensures maximum rigidity for the longer stroke lengths provided on the U-models.

VISION Control

The Vision Control is a ground-breaking and revolutionary press brake control software system. Vision streamlines and simplifies the bending process, giving you full control over every aspect of metal forming.



FEATURES

- Touch screen control
- Automatic bend sequencing
- Automatic tool selection
- Quick tooling change
- Complete control over all axis
- Simple bump bending
- Special bend support such as offset, hemming and pre-bends
- Easily program custom tools



Sketch part profile using touchscreen

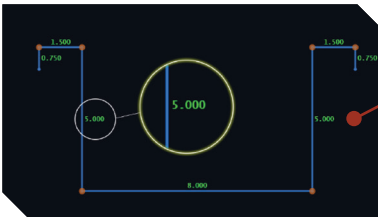

Easily add dimensions and angles



Confirm bend sequence and tooling

Begin forming

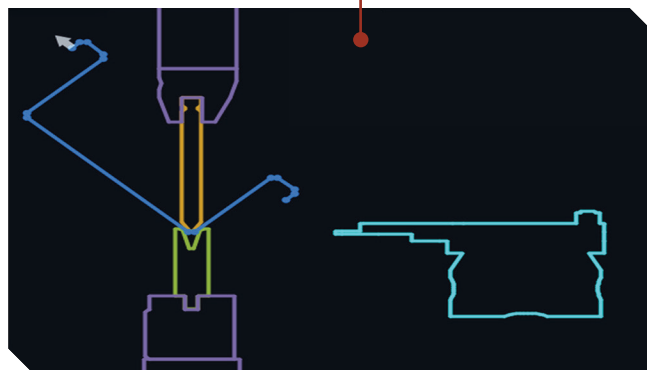

OPTIONAL 3D PACKAGE



VISION 3D

Working with SolidWorks or Inventor, Vision 3D lets you import part models into Vision for full 3D programming, bend visualization, and dynamic viewing during the forming process.

Use VISION in your part models

FEATURES

• Accurate Bend Radius

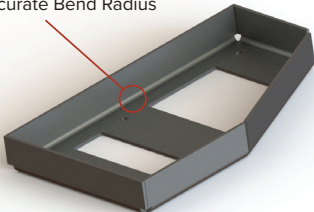

• Accurate Flat Patterns



• Dynamic 3D Bend Simulation

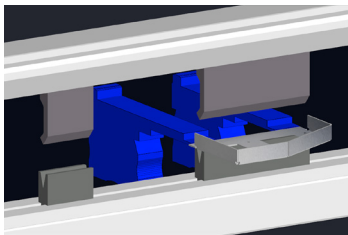

• Run 3D programs on the ETS3000



OPTIONAL BARCODE READER



BARCODE READER

- Two models available:
- 1) Paper-read
 - 2) Paper-read/barcode etched in metal

NOTE: Vision Control required.

BACKGAUGE Options

Accurpress manufactures a variety of excellent Backgauge Systems to best satisfy all bending needs.

PREMIUM Backgauge

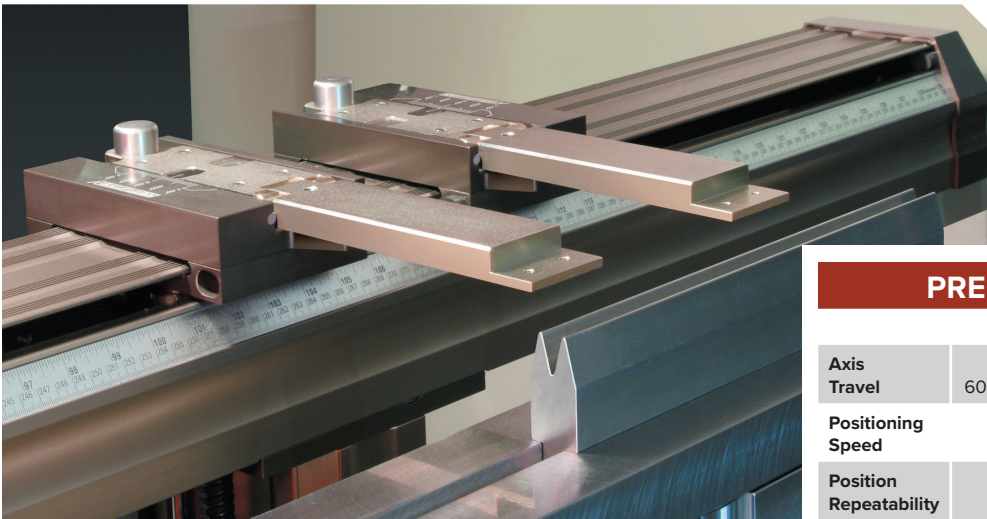

PREMIUM SPECIFICATIONS			
	X-Axis	R-Axis	Z1/Z2-Axes
Axis Travel	24" - 39" 609.6 - 990.6 mm	10" 254 mm	Distance between side frames minus 16"
Positioning Speed	900 ipm	900 ipm	900 ipm
Position Repeatability	+/- 0.001"	+/- 0.001"	+/- 0.003"
Holding Force	750 lbs		

The **Premium** backgauge available for either the Accell-E or Accell-U models offers excellent value and a highly reliable system with power X&R-axes and optional powered Z1/Z2. This gauge is precision-built with solid extrusions, roller carriage castings, and with world-renowned Servo Electric motor/drive packages to offer long-term reliability with minimal maintenance. Additional optional accessories such as extended 39-inch X-axis travel and X-Prime fingers provide increased flexibility for bending applications.

Optional for PREMIUM Backgauge

MANUAL X-Prime



Provides +/- 1" of adjustment via the rotary dial. May be purchased in addition or in lieu of the standard fingers.

POWERED X-Prime



Provides +/- 2" of adjustment via a Schneider motor/drive package and programmed at the Vision or ETS3000 Control.

ELITE Backgauge

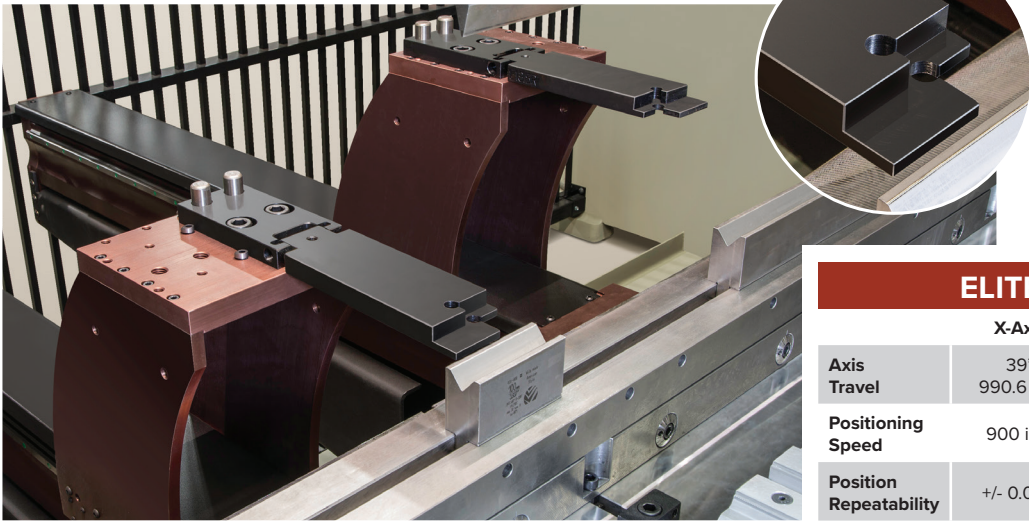

Finger tip contoured for tapered gauging applications

ELITE SPECIFICATIONS			
	X-Axis	R-Axis	Z1/Z2-Axes
Axis Travel	39" 990.6 mm	13" 330.2 mm	Distance between side frames minus 24"
Positioning Speed	900 ipm	900 ipm	900 ipm
Position Repeatability	+/- 0.001"	+/- 0.001"	+/- 0.003"
Holding Force	1500 lbs		

The **Elite**, also offered for the Accell-E or Accell-U models is a powered 6-axis (X1/X2, R1/R2, Z1/Z2) gauge offering increased upgrade flexibility but at affordable pricing levels. This robust design also incorporates world-renowned Schneider Electric motor/drive packages along with two independent gauging platforms mounted on a linear rail to provide efficiency, accuracy, and longevity. Included with the Elite upgrade package is a gate attached to the back of the Accurpress inclusive of a safety interlock switch to meet all applicable safety standards.

Optional for ELITE Backgauge

POP-UP & RETRACT TILTING Sheet Support

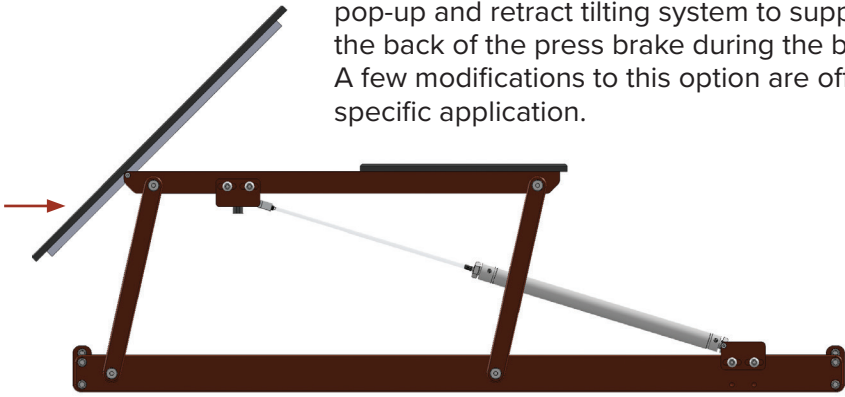
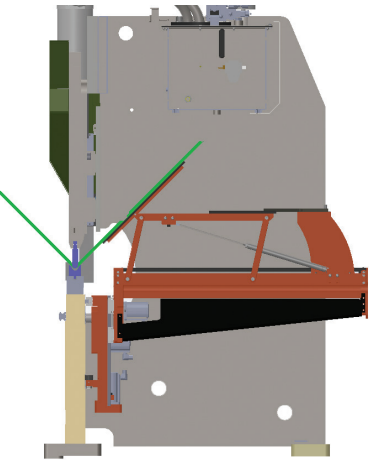

Some forming applications may necessitate a sheet support system attached to the Elite backgauge to support plate with wide flanges. Accurpress has engineered a pop-up and retract tilting system to support the plate at the back of the press brake during the bending cycle. A few modifications to this option are offered to suit the specific application.

SUPREME Backgauge

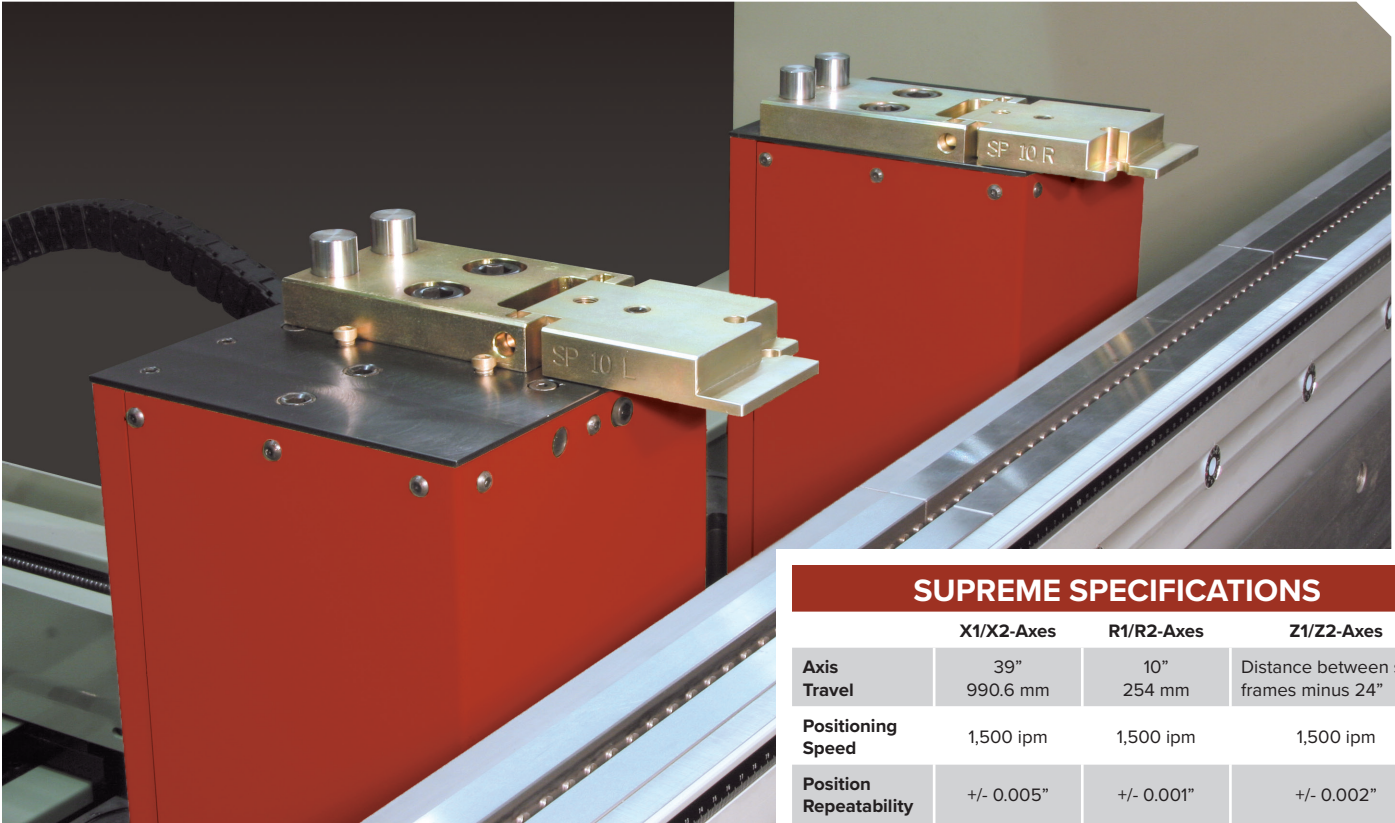

SUPREME SPECIFICATIONS

	X1/X2-Axes	R1/R2-Axes	Z1/Z2-Axes
Axis Travel	39" 990.6 mm	10" 254 mm	Distance between side frames minus 24"
Positioning Speed	1,500 ipm	1,500 ipm	1,500 ipm
Position Repeatability	+/- 0.005"	+/- 0.001"	+/- 0.002"
Holding Force	1,000 lbs		

For applications demanding the most complex sheet metal parts and in high production shops, Accurpress offers the Supreme backgauge available for the Accell-U models. Constructed from a one-piece rugged steel platform that is isolated from the press brake ram movements, the Supreme backgauge is built for optimum accuracy, high speeds on all 6-axes (X1/X2, R1/R2, Z1/Z2) and for years of minimal service requirements. Included with the Supreme backgauge is a rear gate attached to the back of the Accell-U inclusive of a safety interlock switch to meet all applicable safety standards.

To ensure compliance to applicable safety standards, Accurpress installs rear guarding inclusive of a gate with a safety interlock switch on all Accurpress models sold with the Supreme Backgauge.

SUPREME BACKGAUGE

Available with the Accell U Upgrade Package.

TITAN Backgauge

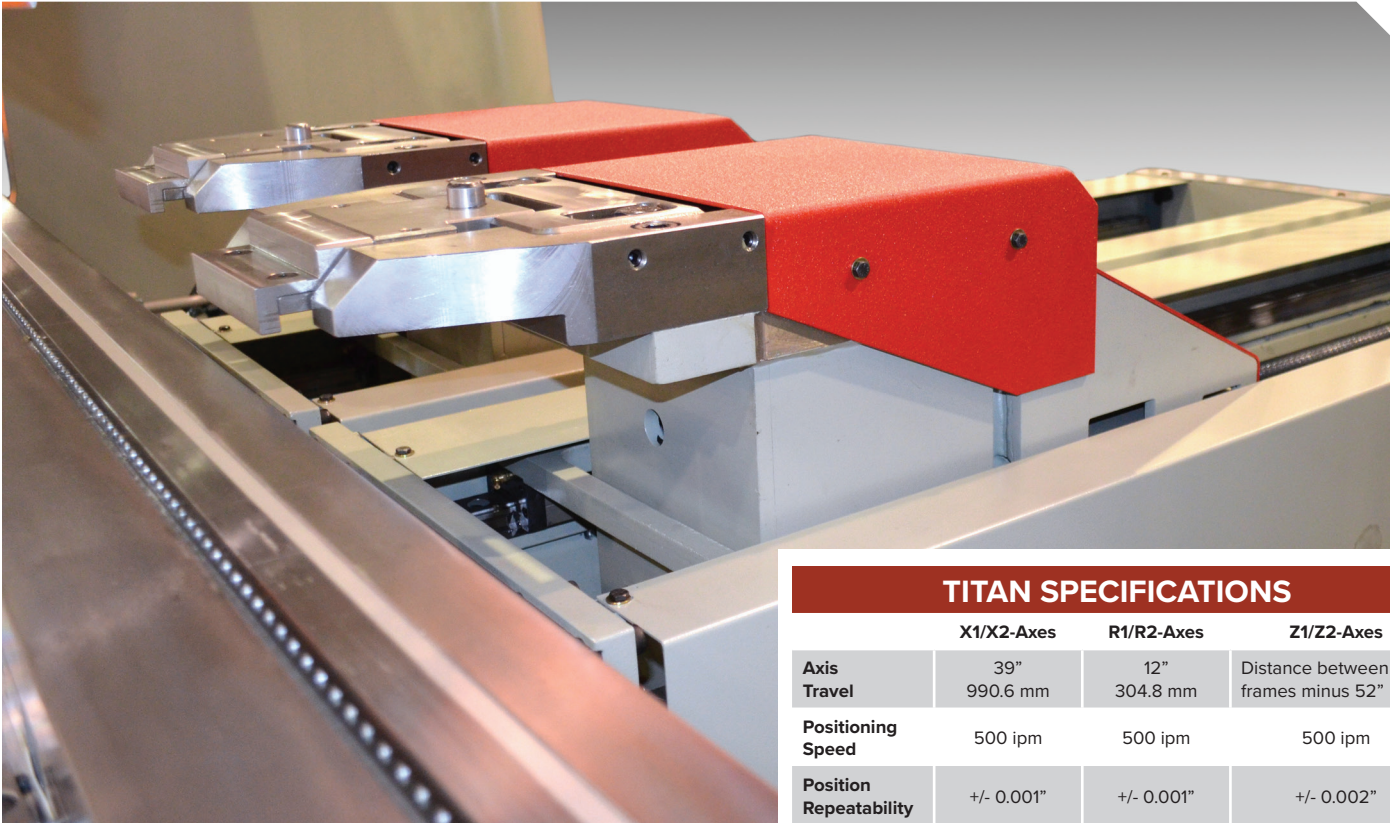

TITAN SPECIFICATIONS			
	X1/X2-Axes	R1/R2-Axes	Z1/Z2-Axes
Axis Travel	39" 990.6 mm	12" 304.8 mm	Distance between side frames minus 52"
Positioning Speed	500 ipm	500 ipm	500 ipm
Position Repeatability	+/- 0.001"	+/- 0.001"	+/- 0.002"
Holding Force	5,000 lbs		

The Titan 6-Axis (X1/X2, R1/R2, Z1/Z2) is the world’s heaviest and strongest gauge built specifically for larger Accell E and U models that are fabricating the most extreme parts! Each component including the oversized fingers have been engineered to withstand the most extreme conditions, shock loads and massive forces from placement of large plates in preparation for final gauging and forming. Each X-axis is capable of 65,000 lbs of static and 20,000 lbs of dynamic load capacity. This rugged backgauge features servo-drive motors, lifetime lubricated precision linear bearings and an unsurpassed ability to handle the heaviest of structural plate applications.

To ensure compliance to applicable safety standards, Accurpress installs rear guarding inclusive of a gate with a safety interlock switch on all Accurpress models sold with the Titan Backgauge.

TITAN BACKGAUGE

The Titan Backgauge is available for larger Accell E and U models.

AiM - Angle Measurement System

To provide the absolute optimum in high precision bending, Accurpress offers AiM - an Angle Measurement System as an optional accessory for the Accell-E, U, and H models. AiM is recommended for demanding applications where minute differences in material thickness, grain direction, or spring-back leave formed parts outside of accepted tolerances. This measurement device operates via sensors that may be positioned anywhere along the length of the tooling to detect material and spring-back differences and makes instant adjustments resulting in highly precise formed pieces.

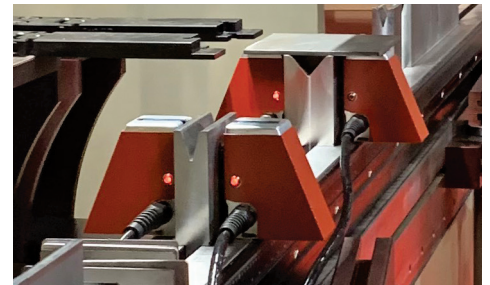
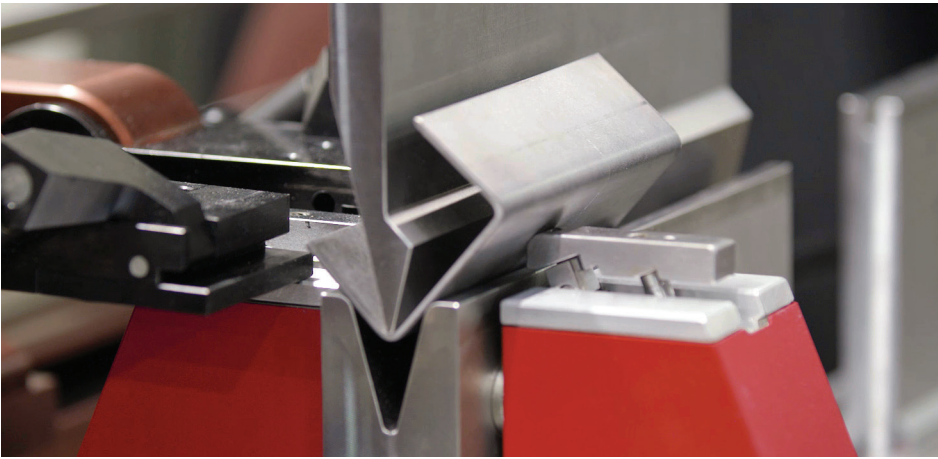

MATERIAL COMPENSATION

INCLUDED WITH THE ACCELL U UPGRADE PACKAGE

Material Thickness Sensing System

During the bending process, the Accell measures variations and inconsistencies in material thickness and then self-adjusts to maintain accurate angle performance.

Teach Crowning

The Teach Crowning feature eliminates the need to manually adjust crowning values via a crowning sensor, which measures machine deflection in real-time and automatically updates the system for the next bend.

Pressure Compensation

The Accell senses variations in pressure between bending with or against the material grain and senses different bend line lengths. Variations can be automatically compensated for, resulting in consistent angle performance.

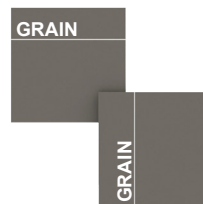
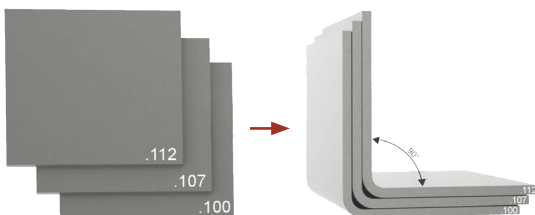

SUPPORT FIXTURES

FRONT SUPPORT ARMS

The Accurpress front support arms come in 24" and 36" lengths and are fully adjustable for different tooling heights and thicknesses. The bottom Foot Disk allows the operator to easily adjust the height of the support arm while the top support piece can be adjusted front to back depending on the desired position. These support arms are mounted on a linear rail for the smooth and accurate positing left to right on the press brake. Both sizes feature angle gauging, squaring bars and disappearing stops.

24" standard size with a protractor. Suitable for models up to and including 4250xx.

36" heavy duty size with a protractor. Recommended for 4350xx and larger models.



SHEET FOLLOWER

The Accurpress Sheet Following System is a moveable support table that lifts and supports material during the bending motion. It is fully synchronized with the ram bend speed and desired angle and can support a load capacity of 500lb per sheet follower. Descent speed and activation of the Sheet Following System are fully programmable by the operator.

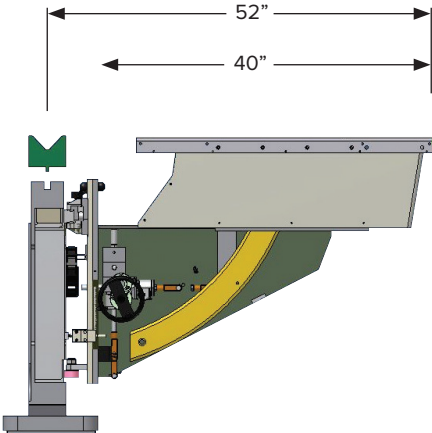

SHEET EXTENDER

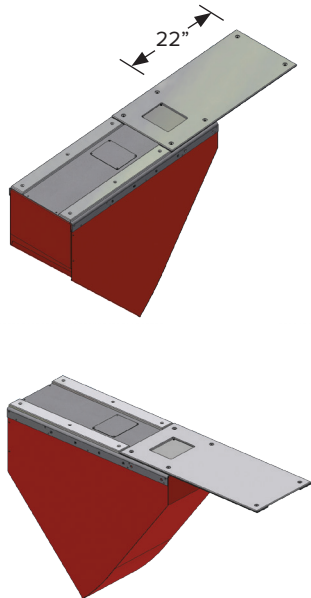

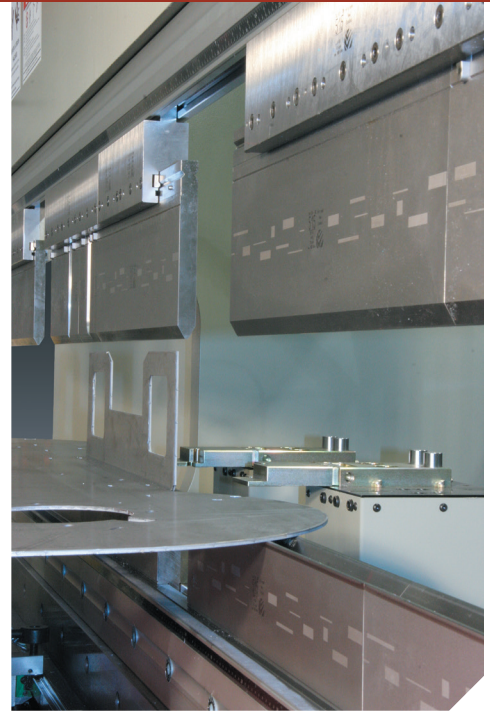

EXTENDED RAM STROKE & OPEN HEIGHTS

To satisfy the bending requirements for deep box forming or additional special forming needs, Accurpress offers optional extended Ram Stroke Lengths—available on the Accell-U models. The Accell-E model may be ordered with additional Ram Open/Closed Heights to enable the optimum height for specific applications and tooling requirements.



EXTENDED THROAT DEPTH

The Accell E and U can be customized to have additional Throat Depth Clearance to facilitate parts with deeper flange lengths.

CUSTOMIZED HORN EXTENSIONS

Accurpress offers customized features such as bed/ram horn extensions for one end or both ends of the Accell E/U models, providing an economical means of adding more bending length and flexibility for the special forming jobs. Optional “Drop-down Vision Control Panel” may be considered in lieu of the “Swing-arm Pendant Mount.”



MOSES CONTROL

This groundbreaking control gives you the powerful features of Vision directly onto the Accurpress Ram. Use the Ram like a touchscreen while Moses easily walks you through the bend process.

- Displays 3D visual of the program during forming
- Use the Ram as a touch screen
- Stunning visual clarity and detail
- A visual guide for tool set ups and part orientation
- Adjust angles and flanges quickly and easily

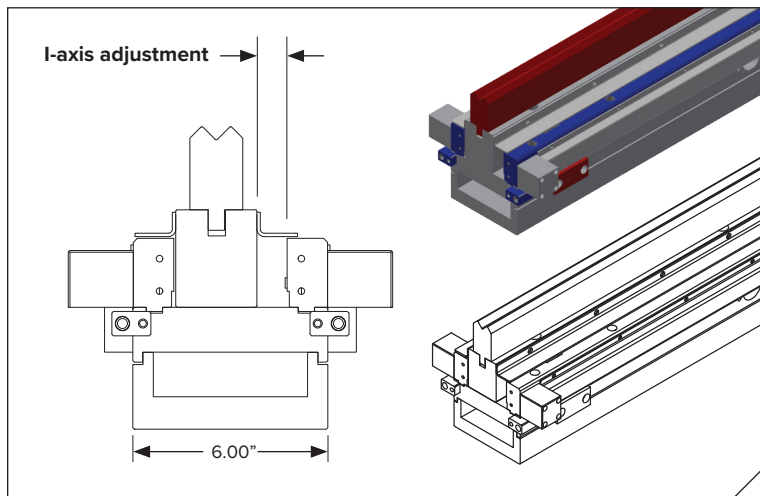

I-AXIS

The I-axis option is advantageous for unique and specialized high production applications that necessitate forward/reverse movement on the Tooling System. Accurpress offers a CNC controlled and air-powered package that provides up to 1" of adjustment in conjunction with the 6" wide Accurcrown. Customization of the I-axis package with wider than 6" Accurcrown Holders and I-axis adjustment greater than 1" are also available upon review of the specific forming job.

TANDEM MODE

All Accell models can be installed in Tandem, where two or more machines operate as one. During operation, the machine controls are electronically connected to exchange information for fully synchronized forming.

This flexible package offered by Accurpress provides the press brake operator the luxury of choosing single machine operation or tandem via a simple selector switch.



ROBOTICS Integration

Accurpress offers robotic press brake solutions for automated bending. Robotized bending combines the Accell press brake with experienced partners in robotics and offline software.

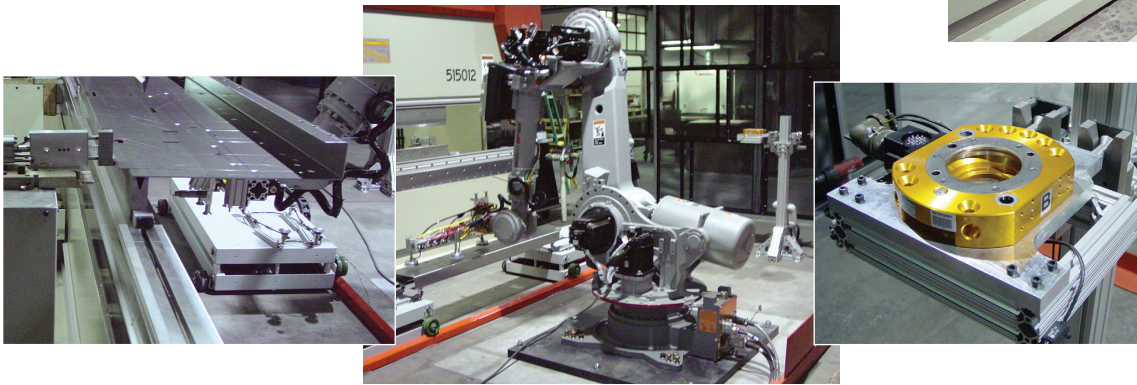

PRECISION TOOLING Systems

Accell-E and U models are sold with a CNC Accurcrown Holder as a standard feature, interfaced with the Vision or ETS3000 control. The Accurcrown is manufactured with a series of precision wedges providing a uniform crown and is anchored to the press brake bed via a universal bolt pattern for maximum rigidity. Lower tool clamping is accomplished manually via set screws in the holder or hydraulically when ordered as an option.



In addition to Crowing Systems, the Accell-E and U models include hydraulic Wila Ram Clamping Systems equipped to handle either American tang-style punches or Wila's large selection of New Standard tang-style punches. As a final complement, Accurpress offers a wide selection of press brake tooling. Choose from standard planner mill dies to high precision, including the complete Wila product line of ultimate exacting standards.

SAFETY GUARDING Systems

LAZERSAFE SENTINEL



Lazersafe Sentinel is a Safety System offered on the Accurpress models that incorporate a continuous dual-beam laser field protection zone directly below the punch tip. The Accurpress will immediately stop if any obstruction is detected when the ram is in motion. This system is most efficient up to 32' ram/bed lengths.



LAZERSAFE SENTINEL PLUS



The Lazersafe Plus includes a dual beam system with a camera as a receiver that recognizes and monitors the silhouette of the punch. The Plus has the added benefit of allowing the ram to operate at fast speeds closer to the pinch point. This system is most efficient up to 18' ram/bed lengths. A Sentinel Plus HL system is available for Accurpress models 20' and longer.



FISSLER AKAS 3F

The Fiessler Laser Guarding System protects the operator from the pinch point hazard of closing tooling. The Fiessler system transmits 3 lasers across the tooling area and monitors any interference as the parts are formed. In the event of an unplanned obstruction in the laser area, the ram is immediately stopped, thereby protecting the operator.



LIGHT CURTAIN GUARDING

Some applications may be best suited to a Light Curtain Guarding System. Accurpress will work with you to recommend a safety system that will provide a secure working environment.

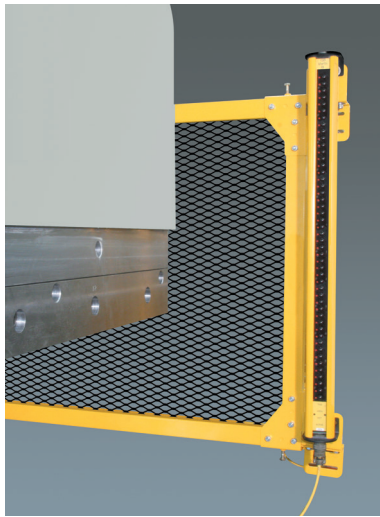

REAR GUARDING

This is a standard feature for all Accurpress HT models that have an Elite or Titan Backgauge. A metal fixture with a gate and a safety interlock switch is installed and safely blocks operator access to the backgauge area. If the operator needs to access the back of the machine, the interlock switch on the gate will prevent the machine from turning on when the door is opened.



ACCELL E Specifications

MODEL NUMBER	TONS	BED HEIGHT	TOP BED WIDTH	RAM OPEN HEIGHT	RAM CLOSED HEIGHT	STROKE LENGTH	OVERALL DIMENSIONS (INCHES)						APPROX. SPEEDS (IN/MIN)			APPROX. SHIPPING WEIGHT (LB)
							A	B	C	D	E	F	APPROACH	BEND	RETURN	
4756	75	34	3	18	8	10	72	54	78	12	60	90	500	24	320	10,000
4758	75	34	3	18	8	10	96	78	102	12	60	90	500	24	320	11,000
47510	75	34	3	18	8	10	120	102	124	12	60	90	500	24	320	13,000
41258	125	34	4	18	8	10	96	78	102	12	60	100	490	24	320	14,000
412510	125	34	4	18	8	10	120	102	124	12	60	100	490	24	320	16,000
412512	125	34	4	18	8	10	144	126	148	12	60	100	490	24	320	18,000
412514	125	34	4	18	8	10	168	148	174	12	63	102	490	24	320	22,000
417510	175	34	4	18	8	10	120	102	124	12	63	102	370	24	280	19,000
417512	175	34	4	18	8	10	144	126	148	12	63	102	370	24	280	22,000
417514	175	34	4	18	8	10	168	148	174	12	63	102	370	24	280	24,000
417516	175	36	8	18	8	10	192	178	204	12	65	108	370	24	280	36,000
417520	175	36	8	18	8	10	240	218	254	12	65	108	370	24	280	48,000
425010	250	36	5	18	8	10	120	102	124	12	65	106	320	24	260	22,000
425012	250	36	5	18	8	10	144	126	150	12	65	106	320	24	260	27,000
425014	250	36	8	18	8	10	168	148	174	12	65	108	320	24	260	32,000
425016	250	36	10	18	8	10	192	172	204	12	65	108	320	24	260	39,000
• 425020	250	36	10	18	8	10	240	218	254	12	65	108	320	24	260	52,000
435012	350	38	10	20	8	12	144	126	156	14	76	122	320	24	240	38,000
435014	350	38	10	20	8	12	168	148	178	14	76	122	320	24	240	43,000
435016	350	38	12	20	8	12	192	172	204	14	76	122	320	24	240	49,000
• 435020	350	38	12	20	8	12	240	218	254	14	76	126	320	24	240	62,000
• 435024	350	38	12	20	8	12	288	266	340	14	76	128	320	24	240	70,000
450012	500	38	10	20	8	12	144	124	156	14	82	130	280	24	220	45,000
450014	500	38	10	20	8	12	168	146	178	14	82	130	280	24	220	52,000
• 450016	500	38	12	20	8	12	192	170	204	14	82	130	280	24	220	58,000
• 450020	500	38	12	20	8	12	240	218	254	14	82	134	280	24	220	70,000
• 450024	500	38	12	20	8	12	288	266	340	14	82	136	280	24	220	82,000

Dimensions are for reference only and subject to change. Machine shipping widths and weights may change pending optional accessories.
 • MODELS REQUIRE BELOW FLOOR LEVEL BED.

Dimensions

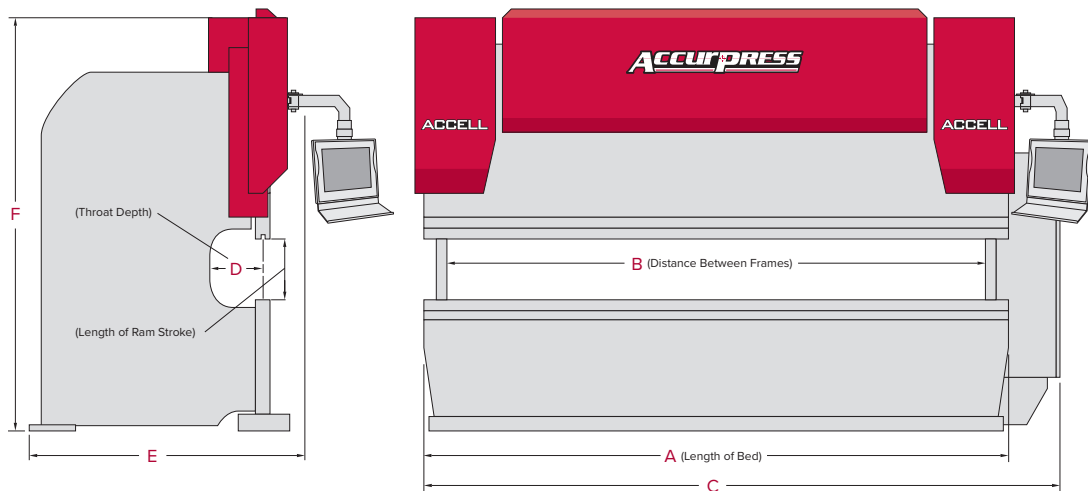

ACCELL U Specifications

MODEL NUMBER	STD TONS	MAX TONS	BED HEIGHT	TOP BED WIDTH	RAM OPEN HEIGHT	RAM CLOSED HEIGHT	STROKE LENGTH	OVERALL DIMENSIONS (INCHES)						APPROX. SPEEDS (IN/MIN)			APPROX. SHIPPING WEIGHT (LB)
								A	B	C	D	E	F	APPROACH	BEND	RETURN	
5756	75	90	34	4.5	22	8	14	72	58	91	16	76	110	500	24-48	320	14,000
5758	75	90	34	4.5	22	8	14	96	82	115	16	76	110	500	24-48	320	16,000
57510	75	90	34	4.5	22	8	14	120	106	139	16	76	110	500	24-48	320	18,000
51258	125	150	34	4.5	22	8	14	96	82	115	16	78	112	490	24-48	320	19,000
512510	125	150	34	4.5	22	8	14	120	106	139	16	78	112	490	24-48	320	22,000
512512	125	150	34	4.5	22	8	14	144	130	186	16	78	112	490	24-48	320	25,000
512514	125	150	34	4.5	22	8	14	168	154	154	16	78	112	490	24-48	320	29,000
517510	175	190	34	4.5	22	8	14	120	106	139	16	78	118	370	24-48	280	28,000
517512	175	190	34	4.5	22	8	14	144	130	162	16	78	118	370	24-48	280	32,000
517514	175	190	34	5.5	22	8	14	168	154	186	16	78	118	370	24-48	280	36,000
517516	175	190	34	5.5	22	8	14	192	178	210	16	78	118	370	24-48	280	40,000
517520	175	190	34	5.5	22	8	14	240	216	320	16	78	118	370	24-48	280	48,000
525010	250	285	38	5.5	22	8	14	120	102	139	16	85	132	320	24-48	280	32,000
525012	250	285	38	5.5	22	8	14	144	126	160	16	85	132	320	24-48	280	36,000
525014	250	285	38	5.5	22	8	14	168	150	184	16	85	132	320	24-48	280	40,000
525016	250	285	38	12	22	8	14	192	174	210	16	85	132	320	24-48	280	44,000
• 525020	250	285	38	12	22	8	14	240	216	320	16	85	132	320	24-48	280	52,000
535012	350	385	38	12	22	8	14	144	126	160	18	85	138	320	24-48	240	42,000
535014	350	385	38	12	22	8	14	168	148	184	18	85	138	320	24-48	240	46,000
535016	350	385	38	12	22	8	14	192	172	210	18	85	138	320	24-48	240	50,000
• 535020	350	385	38	12	22	8	14	240	218	320	18	85	138	320	24-48	240	62,000
• 535024	350	385	38	12	22	8	14	288	218	340	18	85	138	320	24-48	240	74,000
550012	500	550	38	12	22	8	14	144	124	160	18	92	148	280	24	220	52,000
550014	500	550	38	12	22	8	14	168	146	184	18	92	148	280	24	220	60,000
• 550016	500	550	38	12	22	8	14	192	170	210	18	92	148	280	24	220	66,000
• 550020	500	550	38	12	22	8	14	240	218	320	18	92	148	280	24	220	72,000
• 550024	500	550	38	12	22	8	14	288	266	340	18	92	148	280	24	220	86,000

Dimensions are for reference only and subject to change. Machine shipping widths and weights may change pending optional accessories.
 • MODELS REQUIRE BELOW FLOOR LEVEL BED.

Dimensions

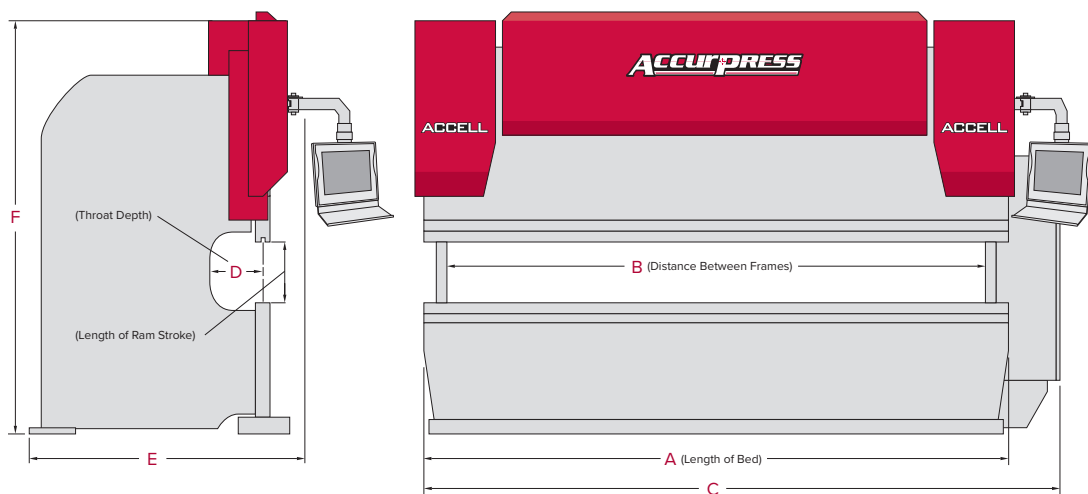

Dealer Support Network

Accurpress Sales & Service is provided by an Authorized Dealer Network. All of our Dealers are factory trained and supported to provide you with knowledgeable, competent, and local service.



© Copyright June 2020

For more information about our products, please refer to our comprehensive brochures or visit our site www.accurpress.com.